



**safety flex**  
ANTI TERRORIST BARRIERS  
[www.safetyflexbarriers.com](http://www.safetyflexbarriers.com)



**Ezi Security Systems**  
SERIOUS SECURITY IS EZI



# INSTALLATIONS AUSTRALIA-WIDE



MELBOURNE



SYDNEY



BRISBANE



CANBERRA

1300 558 304  
11 Cooper St  
Smithfield, NSW 2164  
[www.ezisecurity.com.au](http://www.ezisecurity.com.au)  
[sales@ezisecurity.com](mailto:sales@ezisecurity.com)

## COMPARE OUR PRODUCT

The Public Available Specification (PAS) has been prepared to address the needs of organisations who want assurance that vehicle security barriers will provide the level of impact resistance they are aiming for.

PAS68 identifies impact test methods, tolerances, test vehicle type and vehicle performance criteria that need to be met in order to conform to PAS68. It cites a classification system for the performance of vehicle security barriers and their supporting foundations when subjected to a single horizontal impact.

		1.5 TONNE	7.2 TONNE			7.5 TONNE			18 TONNE		
		48KPH	48KPH (N2A)	64KPH (N2A)	80KPH N2A	80KPH (N3C)	48KPH (N2)	64KPH (N2)	80KPH (N3)	48KPH (N2)	64KPH (N2)
	PAS68 PLANTER (BSI PAS68:2010) V/7500/N2/64/90/2.8/7.2						●				
	CARSTOPPER 30 (BSI PAS68:2010) V/1500(M1)/48/90/1.76/0.0	●									
	TRUCKSTOPPER 3 (BSI PAS68:2007) V/7500/N2/48/90/0.00/0.00 (BSI PAS68:2007) V/7500/N2/48/45/3.3/0.00					●					
	TRUCKSTOPPER 6-30 (BSI PAS68:2010) V/7500/N2/48/90/2.8/0.00					●					
	TRUCKSTOPPER 7-40 (BSI PAS68:2010) V/7500/N2/64/90/7.1/14.8 (IWA 14-1:2013) V/7200(N2A)/64/45:3.3		●				●				
	TRUCKSTOPPER 9-40 IWA 14-1:2013 V/7200/(N2A)64/90/2.4		●								
	TRUCKSTOPPER 9-50 IWA 14-1:2013 V/7200/(N3C)80/90/10.5					●					
	TRUCKSTOPPER 10-30 (IWA 14) V/7200/N2A/48/90/8.2		●								
	SPINGLINE 30/50 (BSI PAS68:2013) V/7200/N2/48/90/3.4/6.4 (IWA14-1:2013) V/7200/N3C/80/90/8.5		●			●					
	SPRINGLINE 30/50 SM (IWA 14-1:2013) V/7200/N3C/80/90/6.8										●
	CRASHBLOCK 40/50 (BSI PAS68:2013) V/7500/N2/64/90/5.5 (IWA14-1:2013) Wall V/7200(N2A)/64/90/6.7 (IWA14-1:2013) Wall V/7200(N3C)/80/90/19.1 (IWA14-1:2013) Wall V/7200(N2A)/48/90/4.1		●	●		●	●				●
	CRASH GATE 40 (IWA14-1:2013 GATE V/7200(N2A)/64/90/3.8			●							
	BRIDGE BOLLARD (IWA14-1:2013 V/7200(N3C)/48/30/1.8					●			●		
	TRUCKSTOPPER R80001-30 (BSI PAS68:2010) V/7500/N2/48/90/3.2/0.00 (BSI PAS68:2010) V/7500/N2/48/45/2.6/0.00						●				
	TRUCKSTOPPER R80002-40 (IWA 14-1:2013) V/7200/(N2A)64/90/1.0		●								
	TRUCKSTOPPER R8003-50 (IWA 14-1:2013) V/7200(N2A)/80/90/3.1				●						

# PAS 68 CRASH TESTED SECURITY PLANTER

## INNOVATIVE LOW COST SOLUTION

### Anti-Terrorist Fixed and Removable Universal Slimline Planter (BSI PAS 68:2010)

#### PLANTER 40 STOPS 7.5 TONNE TRUCK AT 40MPH/64KPH

The Safetyflex universal slimline planter is the worlds smallest crash rated security planter and is the only slimline planter in the marketplace that is universally designed to be made to any sized required. The planter is designed as surface mounted with a shallow foundation. This system is so shallow it reduces the need to re-divert utilities.

This slimline security designed planter can easily fit onto narrow walkways outside banks, train stations, sports stadiums and will not take up large amounts of floor space and is very aesthetically pleasing. One great advantage with this system is the planter is only 100kg in weight so you need no heavy plant to off load or move it into place. The minimum length is 1.48 metre long and the width is 450mm or to whatever the client requires.

The planter has been crash tested to BSI PAS68 to stop a 7.5 tonne truck travelling at 40mph or 64km/h at 90 degrees from breaking through the security

#### CARSTOPPER 30 PAS68 VEHICLE PERFORMANCE CLASSIFICATION

VEHICLE TEST WEIGHT	VEHICLE CLASS	VEHICLE SPEED	VEHICLE ANGLE	VEHICLE PENETRATION	25KG+ DISPERSION
V/7500 KG	N2	64.1	90	2.8	7.2

#### APPLICATION

- ▶ Airport
- ▶ Sports Arenas
- ▶ Retails Parks
- ▶ Police Stations
- ▶ Critical Infrastructure
- ▶ Government Buildings
- ▶ Conference Cnetres

#### KEY FEATURES

- ▶ Shallow Mount Foundation
- ▶ Only 100kg in Weight
- ▶ Design to be made longer and wider as required
- ▶ Guaranteed re-usable after impact
- ▶ Once hit, planter can be removed if needed
- ▶ Low cost installation
- ▶ Bespoke size options available



# UNIVERSAL SLIMLINE PLANTER

PAS 68 CRASH RATED (BSI PAS 68:2010 V/7500(N2)/64/90/2.8/7.2)



NEW INNOVATIVE LOW COST



*"This system is one of the most LOW COST solutions on the market, for crash rated PAS68 Planter and installation cost. (Low cost installation)"*



Why Ezi Security Systems?

- ▶ Ezi Security systems include:
- ▶ Flexibility to design to your requirements
- ▶ Manufacture & supply bespoke on and off products
- ▶ On-site project management and installations
- ▶ Street furniture available on PAS68 and IWA-14
- ▶ High security products available on PAS68-2010 and IWA-14

**Ezi Security Systems**  
UNIQUE SECURITY IS EZI



# CARSTOPPER 30 (BSI PAS68:2010 V/1500 (M1)/48/90/1.76/0.00)

## PAS 68 Low Cost Shallow Mount Single Fixed/Removable Bollard



### Application

- ▶ Airport
- ▶ Sports Arenas
- ▶ Retails Parks
- ▶ Police Stations
- ▶ Critical Infrastructure
- ▶ Government Buildings
- ▶ Conference Cnetes

*"ZERO penetration upon impact from 90° angle"*

## CARSTOPPER 30



(Low cost single shallow mount removable bollard)

Carstopper 30 is a shallow mount single removable bollard. This new patent pending design is a technology break-through in shallow mount single removal bollard. This can be fitted in a single or long runs, it is the only 200 deep single removable car park bollard in the market to date. It is an ideal solution to protect the retail shops, banks, sports stadiums, cash machine (atm's) and all accidental impacts.

This bollard is an ideal anti-ram bollard solution. It is tested for Anti-terrorist protection, giving you the highest specification available. On low impacts the spring bollard will not need replacing as it will return to its original position. The shallow foundation will reduce the need to re-divert utilities. The system is small and easy to install keeping installation cost low. Once fitted and covered with a stainless steel shroud it is aesthetically pleasing and will need no maintenance, for access to maintenance area the bollard can be removed easily.

### CARSTOPPER 30 PAS68 VEHICLE PERFORMANCE CLASSIFICATION

VEHICLE TEST WEIGHT	VEHICLE CLASS	VEHICLE SPEED	VEHICLE ANGLE	VEHICLE PENETRATION	25KG+ DISPERSION	FOOTING DEPTH
V/1500 KG	M1	48	90	0.0	1.76	200

# CARSTOPPER 30 (BSI PAS68:2010 V/1500 (M1)/48/90/1.76/0.00)

## PAS 68 Low Cost Shallow Mount Single Fixed/Removable Bollard

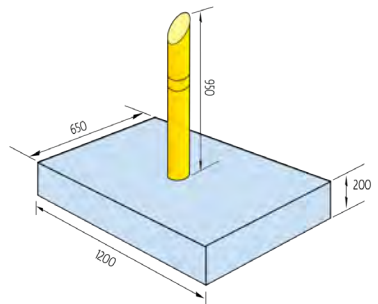

### Product Specification:

Height above ground: 850mm

Footing Depth: Only 73mm

Options: Stainless steel & mild steel shroud available





# TRUCKSTOPPER 3 (BSI PAS68:2010 V/7500 (N2)/48/90/0.0/0.0; BSI PAS68:2010 V/7500 (N2)/48/45/3.3/0.0)

## PAS 68 Low Cost ZERO Penetration High Security Spring Bollards System



### Application

- ▶ Airport
- ▶ Sports Arenas
- ▶ Retail Parks
- ▶ Police Stations
- ▶ Critical Infrastructure
- ▶ Government Buildings
- ▶ Conference Centres

*“ZERO penetration upon impact from 90° angle”*

## TRUCKSTOPPER 3



The new low-cost Truckstopper 3 is the ideal solution for perimeter fencing or as stand alone bollards. It is designed to meet the threat of anti terrorist attacks and can be assembled easily and quickly.

Truckstopper 3 post foundations are only 400mm deep and 1m wide. This security solution was successfully tested at MIRA to BSI PAS68:2007 with a 7.5 tonne truck at 30mph (48kph)

Truckstopper is designed to rival existing add on like perimeter fences or street furniture design for quick fitting. Once installed, it needs no ongoing adjustment. Needing only repainting, the spring steel is crafted to stand 20 year weathered conditions. The bollard can be fitted with either a mild steel shroud (as above) or a stainless steel shroud.

TRUCKSTOPPER 3 PAS68 VEHICLE PERFORMANCE CLASSIFICATION						
VEHICLE TEST WEIGHT	VEHICLE CLASS	VEHICLE SPEED	VEHICLE ANGLE	VEHICLE PENETRATION	25KG+ DISPERSION	FOOTING DEPTH
V/7500 KG	N2	48	90	0.0	0.0	400
V/7500 KG	N2A	48	45	3.3	0.0	400



# TRUCKSTOPPER 3

(BSI PAS68:2010 V/7500 (N2)/48/90/0.0/0.0; BSI PAS68:2010 V/7500 (N2)/48/45/3.3/0.0)

## PAS 68 Low Cost ZERO Penetration High Security Spring Bollards System



### ZERO PENETRATION ANTI-TERRORIST HIGH SECURITY SPRING BOLLARDS



Safetyflex also offer a selection of shrouds and street furniture. Details available on request

#### Product Specification:

Height above ground: 900mm

Footing Depth: Only 400mm

Options: Stainless steel & mild steel shroud available

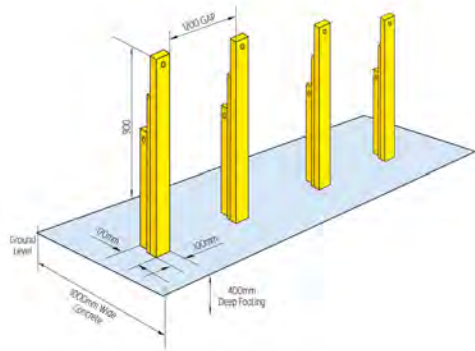

Spring bollard arrangement

# TRUCKSTOPPER 6-30 (BSI PAS68:2010 V/7500 (N2)/48/90/2.8/0.00)

## PAS 68 Low Cost Shallow Mount Single Fixed/Removable Bollard



### Application

- ▶ Airport
- ▶ Sports Arenas
- ▶ Retails Parks
- ▶ Police Stations
- ▶ Critical Infrastructure
- ▶ Government Buildings
- ▶ Conference Cnetres

## TRUCKSTOPPER 6-30

(Single shallow mount fixed/removable bollard)

The new technology TRUCKSTOPPER 6-30 has a small super light weight base plate - 46kg only. This patent pending design is a technology breakthrough in a removable single shallow footing bollard systems of 200mm deep, that will stop a 7.5 ton truck at 10 mph or 48 km at 90 degrees from breaking through the security line. If access is needed the bollard can be removed in minutes.

The 200mm deep single shallow bollard will also reduce the need to re divert utilities. The system is the most economical on the market and very aesthetically pleasing. This bollard is small and easy to install. This system is designed to follow the contours of the ground and can go around corners. If the post gets damaged after an attack they can be removed from the slipper box and replaced with no need to remove or replace the concrete foundation.

Once fitted the only maintenance is to repaint when needed or the bollard can be covered with a mild or stainless steel shroud.

### TRUCKSTOPPER 6-30 PAS68 VEHICLE PERFORMANCE CLASSIFICATION

VEHICLE TEST WEIGHT	VEHICLE CLASS	VEHICLE SPEED	VEHICLE ANGLE	VEHICLE PENETRATION	28KG DISPERSION	FOOTING DEPTH
V/7500 KG	N2	48	90	2.8	0.00	200

*“New Technology breakthrough - foundation only 200mm deep”*

TRUCKSTOPPER 6-30 (BSI PAS68:2010 V/7500 (N2)/48/90/2.8/0.00)

# PAS 68 Low Cost Shallow Mount Single Fixed/Removable Bollard



Supplier of anti-terrorist bollards across Australia and worldwide



*Safetyflex also offer a selection of shrouds and street furniture. Details available on request*

## Product Specification:

Height above ground: 900mm

Footing Depth: Only 200mm

Options: Stainless steel & mild steel shroud available

*Spring bollard cover side view.*

*Spring bollard front side view.*

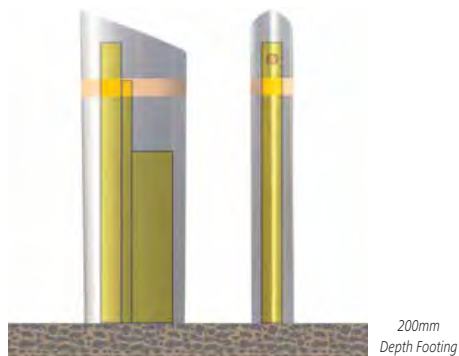

*Foundation only 200mm deep x 900mm wide x 1200mm long.  
Tested and passed as a single removable bollard*

*200mm  
Depth Footing*

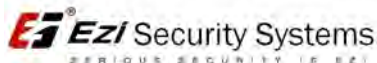



# TRUCKSTOPPER 7-40

(BSI PAS68:2010 V/7500 (N2)/64/90/7.1/14.8; IWA 14-2013 BOLLARD V/7500 (N2A)/64/45:3.3)

## PAS 68 Low Cost Shallow Mount Single Fixed/Removable Bollard



## TRUCKSTOPPER 7-40

(Single shallow mount fixed/removable bollard)

The new technology TRUCKSTOPPER 7-40 has a small and super light weight base plate (46kg only). This patent pending design is a technology break through in a removable single shallow footing bollard systems of 200mm deep that will stop a 7.5 tonne truck at 40 mph or 64kph at 90 degrees from breaking through security line. If access is needed the bollard can be removed in minutes.

The 200mm deep shallow single bollard will also reduce the need to re-divert utilities. The system is the most economical on the market and very aesthetically pleasing. This system is the most economical on the market and very aesthetically pleasing. This bollard is small and easy to install. This system is designed to follow the contours of the ground and can go around corners. If the posts gets damaged after an attack they can be removed from the slipper box without removing or replacing the concrete foundation.

Once fitted the only maintenance is to repaint when needed or the bollard can be covered with a mild or stainless steel shrouds

### Application

- ▶ Airport
- ▶ Sports Arenas
- ▶ Retail Parks
- ▶ Police Stations
- ▶ Critical Infrastructure
- ▶ Government Buildings
- ▶ Conference Centres

*"New Technology breakthrough - foundation only 200mm deep"*

### TRUCKSTOPPER 7-40 PAS68 VEHICLE PERFORMANCE CLASSIFICATION

VEHICLE TEST WEIGHT	VEHICLE CLASS	VEHICLE SPEED	VEHICLE ANGLE	VEHICLE PENETRATION	25KG+ DISPERSION	FOOTING DEPTH
V/7500 KG	N2	64	90	7.1	14.8	200
V/7200 KG	N2A	64	45	3.3		200



# TRUCKSTOPPER 7-40

(BSI PAS68:2010 V/7500 (N2)/64/90/7.1/14.8; IWA 14-2013 BOLLARD V/7500 (N2A)/64/45:3.3)

## PAS 68 Low Cost Shallow Mount Single Fixed/Removable Bollard



Supplier of anti-terrorist bollards across Australia and worldwide



Safetyflex also offer a selection of shrouds and street furniture. Details available on request

Spring bollard cover side view.

Spring bollard front side view.

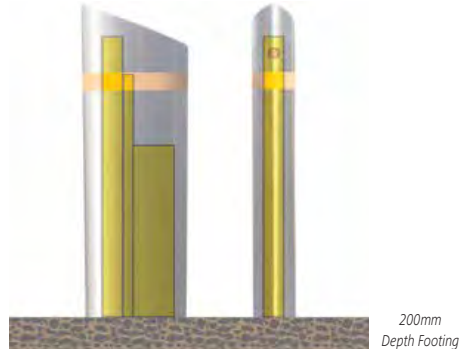

Foundation only 200mm deep x 900mm wide x 1200mm long.  
Tested and passed as a single removable bollard

200mm  
Depth Footing

### Product Specification:

Height above ground: 900mm

Footing Depth: Only 200mm

Options: Stainless steel & mild steel shroud available

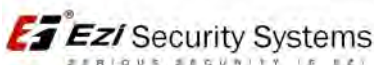

# TRUCKSTOPPER 9-40 Super shallow foundation Only 200mm deep

## IWA 14 CRASH RATED 40MPH BOLLARD

(IWA 14-2013 BOLLARD V/7200 (N2A)/64/190:2.4)



**CRASH RATED 7200KG AT 40MPH/64KPH ' SUPER SHALLOW FOUNDATION ONLY 200 DEEP**  
**THIS BOLLARD IS THE SMALLEST AND CHEAPEST (N2A)**  
**40 PMH BOLLARD SYSTEM ON THE MARKET TODAY**



**AT LAST A NEW DESIGN THAT DOES ALL THIS...**

### Application

- ▶ Airport
- ▶ Sports Arenas
- ▶ Retail Parks
- ▶ Police Stations
- ▶ Critical Infrastructure
- ▶ Government Buildings
- ▶ Conference Centres

- ▶ Shallow foundation only 200mm deep - Reducing the need to re-divert utilities
- ▶ Bollard overall height out of the ground is only 950mm
- ▶ This bollard can be fixed or removable
- ▶ Comes in break down kits allowing for ease of transport and installation - keeping costs down
- ▶ Very aesthetically pleasing
- ▶ Crash-tested product with only 2.4m penetration - the worlds shortest penetration in its foundation class.

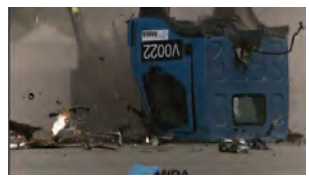

TRUCKSTOPPER 9-40 IWA=14 VEHICLE PERFORMANCE CLASSIFICATION						
Vehicle Test Weight KG	Vehicle Class	Vehicle Speed kph	Vehicle Angle °	Vehicle Penetration	Footing Depth mm	
V/7200	[N3C]	80	90	10.5	200	



# TRUCKSTOPPER 9-40 Super shallow foundation Only 200mm deep

## IWA 14 CRASH RATED 40MPH BOLLARD

(IWA 14-2013 BOLLARD V/7200 (N2A)/64/190:2.4)

FOUNDATION  
200MM Deep

BOLLARD ONLY  
1000 HIGH

REMOVABLE  
BOLLARD

This new Anti Terrorist Bollard, has been designed with the added advantage that the slipper box or (post socket box) can be moved separately and is not rigid. The box can be swivelled around a corner of 90 degrees or more if needed and can adapt to an up and down slopping surface without having to change the box design



2018 AUSTRALIAN SECURITY INDUSTRY PRODUCT OF THE YEAR (PHYSICAL SECURITY)  
A SECURITY SOLUTION TESTED TO PROTECT WITH PERFORMANCE  
AS WORLD'S SHORTEST PENETRATION AMONG ITS CLASS

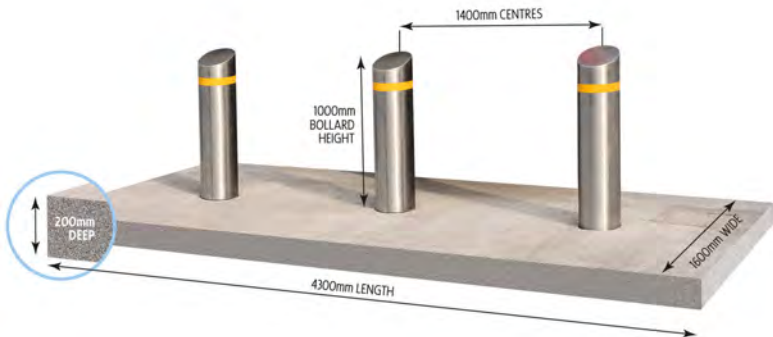

**Ezi Security Systems**  
SERIOUS SECURITY IS EZI

**PSSA**  
Perimeter Security Suppliers Association

**ASIAL**  
ASIAN SECURITY ASSOCIATION



# IWA 14 CRASH RATED 50MPH BOLLARD TRUCKSTOPPER 9-50 Super shallow foundation Only 200mm deep IWA 14-1:2013 Bollard V/7200[N3C]/80/90:10.5



**CRASH RATED 7200KG AT 50mph/80kph 'SUPER SHALLOW FOUNDATION ONLY 200mm DEEP'  
THIS BOLLARD IS THE SMALLEST AND CHEAPEST  
(N3C) 50MPH BOLLARD SYSTEM ON THE MARKET TODAY**



## Application

- ▶ Airport
- ▶ Sports Arenas
- ▶ Retail Parks
- ▶ Police Stations
- ▶ Critical Infrastructure
- ▶ Government Buildings
- ▶ Conference Centres

## AT LAST A NEW DESIGN THAT DOES ALL THIS...

- ▶ Shallow foundation only 200mm deep - Reducing the need to re-divert utilities
- ▶ Bollard overall height out of the ground is only 950mm
- ▶ This bollard can be fixed or removable
- ▶ Comes in break down kits allowing for ease of transport and installation - keeping costs down
- ▶ Very aesthetically pleasing



### TRUCKSTOPPER 9-50 IWA=14 VEHICLE PERFORMANCE CLASSIFICATION

Vehicle Test Weight KG	Vehicle Class	Vehicle Speed kph	Vehicle Angle °	Vehicle Penetration	Footing Depth mm
V/7200	[N3C]	80	90	10.5	200





# IWA 14 CRASH RATED 50MPH BOLLARD TRUCKSTOPPER 9-50 Super shallow foundation Only 200mm deep

IWA 14-1:2013 Bollard V/7200[N3C]/80/90:10.5

**FOUNDATION  
200MM Deep**

**BOLLARD ONLY  
950 HIGH**

**REMOVABLE  
BOLLARD**

This new Anti Terrorist Bollard, has been designed with the added advantage that the slipper box or (post socket box) can be moved separately and is not rigid. The box can be swivelled around a corner of 90 degrees or more if needed and can adapt to an up and down slopping surface without having to change the box design.



**CRASH RATED 7200KG AT 50mph/80kph 'SUPER SHALLOW FOUNDATION ONLY 200mm DEEP'**  
**THIS BOLLARD IS THE SMALLEST AND CHEAPEST  
(N3C) 50MPH BOLLARD SYSTEM ON THE MARKET TODAY**

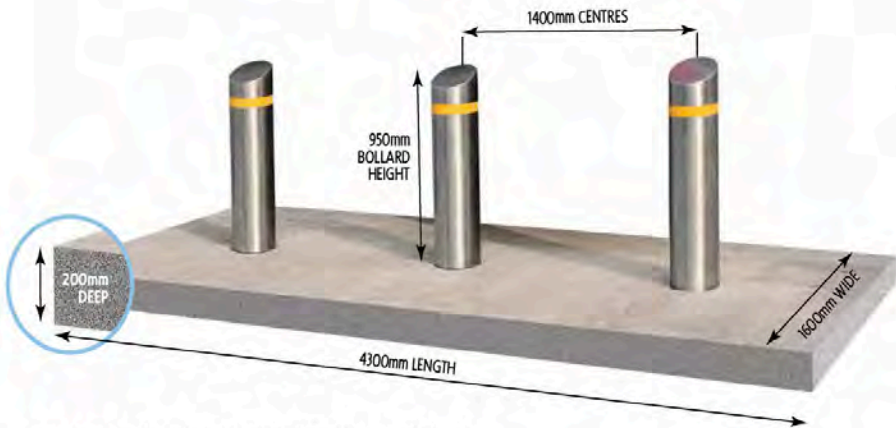

**FOUNDATION SIZE FOR THREE BOLLARD RUN**

*International Patents applied for*

**Ezi Security Systems**  
SERIOUS SECURITY IS EZI

**PSSA**  
Partners Security Suppliers Association

**ASIAL**  
ASIAN SECURITY ASSOCIATION LIMITED

# TRUCKSTOPPER 10-30 (IWA14) V/7200/N2A/48/90/8.2

## IWA 14 Surface Mount Single Removable Bollard



### SURFACE MOUNT SINGLE REMOVABLE BOLLARD



#### Application

- ▶ Airport
- ▶ Sports Arenas
- ▶ Retail Parks
- ▶ Police Stations
- ▶ Critical Infrastructure
- ▶ Government Buildings
- ▶ Conference Centres

*'New technology breakthrough - SURFACE MOUNTED'*

#### 'THE CITY SLICKER' TRUCKSTOPPER 10-30 (surface mount single removable bollard)

This world's first crash tested, surface mounted single bollard, has been crash tested as a single removable bollard, tested to the new international workshop agreement - IWA 14. This surface mount bollard, can be fitted straight onto an existing concrete surface without having to dig up the existing surface and will still give you the full protection of a 7.2 ton vehicle travelling at 30 mph/48kph at 90 degrees without the cost and inconvenience of digging up the roadway or footpath. Once fitted you may need access with a vehicle so the bollards can be removed and replaced very quickly. This system is the **most economical to buy and install on the market today**. It can be a stand alone single unit or can be in a row of bollards. No heavy plant is needed to install as the bollards are delivered as break down kits and can be built up on site. Once fitted **no maintenance is needed** and if covered with a shroud are very aesthetically pleasing.



#### TRUCKSTOPPER 10-30 IWA-14 VEHICLE PERFORMANCE CLASSIFICATION

Vehicle Test Weight KG	Vehicle Class	Vehicle Speed kph	Vehicle Angle °	Vehicle Penetration	Footing Depth mm
V/7200	[N2A]	48	90	8.2	5M

# TRUCKSTOPPER 10-30 (IWA14) V/7200/N2A/48/90/8.2

## IWA 14 Surface Mount Single Removable Bollard



### 'THE CITY SLICKER'



Safteyflex also offer a selection of shrouds and street furniture. Details available upon request.

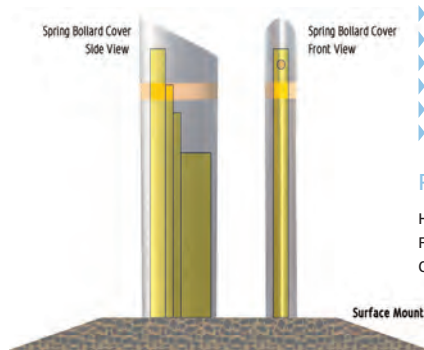

- ▶ Surface mounted
- ▶ No complicated installation
- ▶ Static & Removable
- ▶ Tested to IWA 14
- ▶ Ideal for concrete suspended slabs
- ▶ Crash tested with 7200 kg truck at 30 mph

#### PRODUCT SPECIFICATION

**Height Above the Ground:** 900mm  
**Footing Depth:** Surface Mount  
**Options:** Stainless Steel & Mild Steel Shrouds



# IWA 14 Crash Tested Fence

## SPRINGLINE 30 (BSI PAS68:2010) V/7500[N3C]/48/90:3.4/6.4/400



**Only 400mm Foundation - Fitted and tested in soft ground**



### Application

- ▶ Nuclear Sites
- ▶ Sports Arenas
- ▶ Police Stations
- ▶ Critical Infrastructure
- ▶ Government Buildings
- ▶ Conference Centers

*AT LAST* No need for deep foundations.

*AT LAST* Fitted and tested in soft ground (type 1 stone).

*AT LAST* No heavy transport needed to move it, to and from sites.

*AT LAST* No heavy plant needed to install it.

*AT LAST* The fence system is delivered in breakdown kits with ready-made cages. This newly designed fencing system can be fitted in soft water logged ground or hard ground with only a foundation of 400mm deep. The foundation post blocks are not linked underground so you do not have to run the fence in a straight line. The posts slings have also been designed so they are independently linked to each post so that the system can go up and down slopes and around corners by just moving the slings no special parts are needed to do this as the cable slings are designed short and they are easy to handle and follow the contour of the ground by moving the slings on the posts.

Once the slings are tightened you will have no rope drop in the line. The sling ground height can be set exact to drawing. A great advantage with this system is if you need an access along the fence line you can remove just part of the fence very quickly. Once built you have a very low maintenance and it will look aesthetically pleasing.



CRASH FENCE SPRINGLINE 30 PAS68 VEHICLE PERFORMANCE CLASSIFICATION					
Vehicle Test Weight KG	Vehicle Class	Vehicle Speed kph	Vehicle Angle °	Vehicle Penetration	Footing Depth mm
V/7500	[N2]	48	90	3.4	400



# IWA 14 Crash Tested Fence

## SPRINGLINE 50 IWA14 -2013 FENCE V/7200[N3C]/80/90:8.5

This new generation of crash fence, has been designed to protect perimeters, from any terrorist , criminal or accidental attacks.

The IWA 14 springline 50 crash fence has been designed for hostile vehicle mitigation. Safetyflex Barriers were commissioned to specially design a crash fence, with a very shallow foundation of only 400mm that could be installed into soft ground.

This IWA 14 springline crash fence, is designed to protect key sites, like airports, MOD Bases, oil and gas Infrastructure, or any other facility that requires hostile vehicle mitigation measures along the fence line, from any vehicle attack.

The springline 50 , can be installed in short and long runs, and can stop a 7200 kg truck at 80kph.



### Shallow Mount IWA 14 Crash Tested Fence Only 400mm Foundation

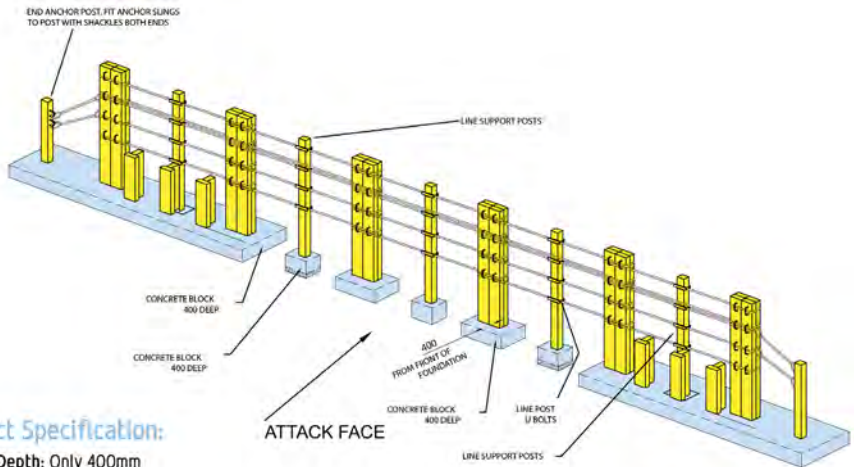

**Product Specification:**  
**Footing Depth: Only 400mm**

*International Patents applied for*

**Ezi Security Systems**  
 SERIOUS SECURITY IS EZI



#### CRASH FENCE SPRINGLINE 50 IWA 14 VEHICLE PERFORMANCE CLASSIFICATION

Vehicle Test Weight KG	Vehicle Class	Vehicle Speed kph	Vehicle Angle °	Vehicle Penetration	Footing Depth mm
IWA 14-1:V/7200	[N3C]	80	90	8.5	400

# SURFACE MOUNTED FENCE

## SPRINGLINE 30 & 50 - SM

### No Surface Fixing Needed

Stops an 18Tonne GVW Truck Travelling at 50mph/80km/h



**Ezi Security Systems**  
SERIOUS SECURITY IS EZI

#### Application

- ▶ Nuclear Sites
- ▶ Sports Arenas
- ▶ Police Stations
- ▶ Critical Infrastructure
- ▶ Government Buildings
- ▶ Conference Centers

- ▶ Crash tested at 80kph (50mph ) with a N3C vehicle-head on attack.
- ▶ Surface mount solution.
- ▶ Safetyflex barriers, are the only company in the world to offer this product.
- ▶ No foundation required.
- ▶ No need to worry about underground services or utilities.
- ▶ No requirements for removal of soils, and contaminated soil.
- ▶ Fast deployment.
- ▶ Most advanced crash rated hostile vehicle mitigation (HVM) solution in the world.

**AT LAST** No foundation needed surface mount solutions.

**AT LAST** No continuance line off concrete blocks.

**AT LAST** No more holes to dig, no soil to remove.

**AT LAST** Fast deployment.

**AT LAST** The fence is designed to with stand attack from both sides.

**AT LAST** If access is needed you just take out part off the fence this will not compromise the whole fence line security.

**AT LAST** Once assemble the area will be fully secured.

# SURFACE MOUNTED FENCE

## SPRINGLINE 30 & 50 - SM

Instant Hostile Vehicle Mitigation Protection

No Surface Fixing Needed.

Stops an 18 Tonne GVW Truck Travelling at 50mph/80km/h

Safetyflex barriers, were commissioned to design a new type of crash fence that would need to be surface mounted and would be required to be tested to the IWA 14 crash ratings, A specific requirement of the test being to stop 7.5 tonne truck traveling at 50mph or 80kph at 90° head on.

Two versions of Springline surface mount crash fence was subsequently developed, Springline 30 crash rated at 30mph/64kph and Springline 50 crash rated at 50mph/80kph.

Both versions are able to stop a vehicle attack from both sides of the fence with no continuous concrete blocks or steel barriers. Designed for rapid deployment at public realm projects such as football stadiums, German markets etc it has also been specially designed for nuclear sites and government and key infrastructure sites that demand a no dig policy where foundation solutions are not an option. Available for temporary or permanent solutions, 50 metres of fence can be assembled in 4 hours and removed in 2 hours.

PROVIDING INSTANT H.V.M PROTECTION both product versions, have been successfully crash. Tested with a N3C vehicle, an 18,000kg 2 axle rigid (Which is classed as worst scenario, within this range of testing).

- ▶ Safetyflex barriers, are the only company in the world to offer this product.
- ▶ No requirements for removal of soils, and contaminated soil.
- ▶ No foundation required
- ▶ Fast deployment
- ▶ No need to worry about underground services or utilities.
- ▶ Most advanced crash rated hostile vehicle mitigation (H.V.M) solution in the world

SPRINGLINE 30 & 50-SM					
Vehicle Test Weight	Vehicle Class	Vehicle Speed kph	Vehicle Angle *	Vehicle Penetration m	Footing Depth mm
V/7200 KG	N3C	80	90	6.8	SURFACE MOUNTED
V/7200 KG	N2A	48	90	5.4	SURFACE MOUNTED

 **Ezi Security Systems**  
SERIOUS SECURITY IS EZI



# CRASH BLOCK 40 TESTED TO IWA 14

THE WORLD'S MOST VERSATILE SURFACE MOUNT,

**FREE STANDING CRASH RATED BLOCK STOPS A 7.5 TONNE TRUCK TRAVELLING AT 40MPH/64KPH**

Crash Block 40 is a Surface Mount Block that has a special unique design that lets the block just sit on the surface of the ground with no ground fixing. It is completely free standing.

Three High Speed Impact Tests was carried out on the block at (Horiba Mira) UK, Vehicle Impact Testing Centre to BSi IWA14 N2A Impact test. The first test was at 30mph/48km/h at 90 Degrees into the front face of the block. The second test was 40mph/64km/h at 90 Degrees into the front face of the Block. The third impact test was at 90 degrees into a gap of 1.2 meters between the two blocks at a speed of 30mph/48km/h with 7.5ton truck crashing into the gap, with a result of 2.9 Penetration only.

The great advantage with Crash Block 40-Plus it can be permanent or temporary solutions as it only takes hours to install. They can also be dressed in a cladding of choice or fitted with a Planter with seating benches. All work can be done without disturbing existing ground work. NO requirements for foundation.



## CRASH TESTED AT 30MPH

IWA14-1: 2013BLOCKV/7200[N2A]/48/90:4.1 FRONT FACE  
IWA14-1: 2013BLOCKV/7200[N2A]/48/90:42.9 FRONT FACE Into Gap

## CRASH TESTED AT 40MPH

IWA 14 -1: 2013 WALL V/7200[N2A]/64/90:6.7 FRONT FACE  
ASTM F2656 M40-P2  
PAS68-1:2013 V/7500[N2]/64/90:5.5  
CWA16221 V/(N2)7500/64/90:6.7





# CRASH BLOCK 50 TESTED TO IWA 14

THE WORLD'S ONLY HIGH SPEED MULTIPLE CRASH TESTED BLOCK,  
**FREE STANDING CRASH RATED BLOCK** STOPS A 18  
TONNE TRUCK TRAVELLING AT 50MPH/80KPH

The world's only high speed (BSI IWA14) Multiple Crash Tested Surface Mount Crash Block:

As the growing threat of Terrorist Attacks on the public gets worse, new ways of stopping them have been developed by Safetyflex's design team to give instant H.V.M Protection. Crash Block 50 is a surface mount block that has a special, unique design that lets the block just sit on the surface of the ground with no ground fixing. It is completely free standing and can stop a 18 tonne GVW truck travelling at 50mph/80km/h.

Four high speed impact tests were carried out on the block at (Horiba Mira) UK, vehicle impact tested centre to BSI IWA14 impact test. The first test was at 30mph/48kph at 90 degrees with a 7.5 tonne truck into the front face of the block. The second test was 40mph/64kph at 90 degrees with a 7.5 tonne truck into the face of the block. The third test was an 18 tonne truck at 50mph/80kph at 90 degrees into the end face of the block. All tests were carried out on the same block.

## BONUS TEST

The blocks were impact tested at 90 degrees into a gap of 1.2 meters between the two blocks at a speed of 30mph/48kph with a 7.5 tonne truck crashing into the gap with a result of 2.9m penetration only.

The great advantage with Crash Blocks are that they can be permanent or temporary solutions as it only takes hours to install. They can also be dressed in a cladding of choice, or fitted with a planter with seating benches. All work can be done without disturbing existing ground work.



## CRASH TESTED AT 50MPH

IWA 14 -1: 2013 WALL V/7200[N3C]/80/90:19.1 END FACE  
IWA 14 -1: 2013 WALL V/7200[N2A]/64/90:6.7 FRONT FACE  
IWA 14 -1: 2013 WALL V/7200[N2A]/48/90:4.1 FRONT FACE  
IWA 14 -1: 2013 WALL V/7200[N2A]/48/90:2.9 FRONT FACE Into Gap  
ASTM F2656 M40-P2  
PAS68-1:2013 V/7500[N2]/64/90/5.5



Block Covers



International  
Patents  
Applied for

**Ezi Security Systems**  
SERIOUS SECURITY IS EZI



**NEW  
PRODUCT**

# SURFACE MOUNT H.V.M CRASH GATE-40

IWA 14 CRASH TESTES TO STOP A 7.2 Tonne Truck Travelling  
at 40mph/64kph at 90°



**No Pinning to the surface H.V.M install in 2 hours**



## Application

- ▶ Airport
- ▶ Sports Arenas
- ▶ Retails Parks
- ▶ Police Stations
- ▶ Critical Infrastructure
- ▶ Government Buildings
- ▶ Conference Cnetres



## Secure, reliable and highly effective...

The Safetyflex design team have responded to clients' requirement for a new type of surface mount gate that can be installed within 4 hours, with no man handling to operate the gate. The gate will open horizontally to save ground space.

This brand new surface mount gate developed by the Safetyflex design team gives instant HVM protection and the ability to close off roads within hours. The new unique Crash Gate 40 system was crash tested at Horiba-Mira crash centre to IWA-14-1 vehicle impact test with a 7.5 tonne truck travelling at 40mph/64km/h at 90 degrees and stops the vehicle in 3.8 metres.

There is no man handling needed to open the gate. The gate operates using an all solar powered electric hydraulic power system and two batteries but can be installed to mains electric if needed. The gate opening time is only 75 seconds and once fully open the pass through gap is 4.5 metres. As well as stopping a truck the gate is also designed to stop a small car from driving under it.

CRASH GATE 40						
Vehicle Test Weight	Vehicle Class	Vehicle Speed kph	Vehicle Angle °	Vehicle Penetration	25kg+ Dispersion m	Footing Depth mm
IWA 14-1:V7200	[N2A]	64	90	3.8	0.00	450

**Ezi Security Systems**  
SERIOUS SECURITY IS EZI



NEW  
PRODUCT

# ULTRA SHALLOW ANTI-TERRORIST BRIDGE BOLLARDS

Crash Tested to Stop a 18 Tonne (GVW) Truck Travelling at  
30mph/48m/h 30°



## No Pinning to the Bridge Deck

### KEY ELEMENTS IN OUR DESIGN

Our key elements in our design, and in our brief to our design team:

- ▶ Keep the design, aesthetically pleasing
- ▶ Have Ultra-shallow topping (of only 80mm deep) with no deck fittings
- ▶ Must stop the LARGE TRUCK (N3C vehicle, 18 tonne Gross Vehicle Weight) which replicates the size of a large London bus
- ▶ It must be a light weight system, and not over engineered
- ▶ Heritage style bollards and modern
- ▶ Must be designed to be the most cost effective bollards HVM solution



Safetyflex Barriers have been commissioned and tasked to design a new ultra-shallow anti-terrorist bollard for protecting London Bridges from Vehicle Terrorist Attacks.

Safetyflex design team have once again designed the next generation of bollard, with their specialist designs and energy absorption materials they have designed a new type of bollard that requires:

- ▶ Light Weight Designed Bollard System for High Speed Install
- ▶ An Ultra Shallow Topping of "Only 80mm Deep"
- ▶ No pinning to the bridge deck
- ▶ 80mm Topping Only

Safetyflex's new Truckstopper Bridge Bollard has been tested to IWA14, to stop an 18 ton vehicle (N3C) At 30mph with the attack impact at 30 Degrees, with only 80mm Topping. It has been designed with the idea of using single heritage-style bollards that will create separate space for cyclists across the bridge, and enough space for all other bridge users.

#### BRIDGE BOLLARD 40

Vehicle Test Weight	Vehicle Class	Vehicle Speed kph	Vehicle Angle °	Vehicle Penetration	25kg+ Dispersion m	Footing Depth mm
IWA 14-1:V/7200	[N2A]	64	90	3.8	0.00	450

**Ezi Security Systems**  
SERIOUS SECURITY IS EZI

**PSSA**  
Professional Security Solutions Australia

**ASIAL**  
ASIAN SECURITY AUSTRALIA

# PAS68 / IWA-14 CRASH TESTED SLIMLINE RISING BOLLARD RB001-30

## NO MAIN POWER REQUIRED

Stops a 7.5 Tonne Truck Travelling at 30mph/48km/h



### Application

- ▶ Airport
- ▶ Sports Arenas
- ▶ Retail Parks
- ▶ Police Stations
- ▶ Critical Infrastructure
- ▶ Government Buildings
- ▶ Conference Centers

The new technology breakthrough in SHALLOW MOUNT RISING BOLLARD systems keeps ground work costs to a fraction of the old large systems. This new bollard rising systems is designed by our new Micro Engineering Division to cope with today's demand for shallow mount systems in both manual and hydraulic.

RB001-30 requires no main power. It is POWERED BY A VOLT CORDLESS DRILL. This shallow rising bollard has capacity to stop a 7.5 ton truck at 30mph or 48kph at 90 degrees and 45 degrees from breaking through the security lines. This system will also reduce the need to re-divert utilities. The system is the most economical on the market for both bollard systems and installation. It is also very low maintenance, once fitted as a stand alone unit, it can follow the contours of the ground. After impact, any damaged parts above the foundation are removable and can be replaced. When fitted with a stainless steel bollard cover, this system is very aesthetically pleasing.

### Product Specification

- ▶ Height Above Ground: 850mm
- ▶ Footing Depth: Only 400mm
- ▶ Options: Stainless Steel & Mild Steel
- ▶ Shrouds Available

*"Tested to stop a  
7.5tonne truck travelling  
at 48 kph at 90° and 45°"*

#### RB001-30 Slimline Rising Bollard

Vehicle Test Weight	Vehicle Class	Vehicle Speed kph	Vehicle Angle °	Vehicle Penetration	25kg+ Dispersion m	Footing Depth mm
PAS68: V/7500	[N2]	48	90	3.2	0.00	450
PAS68: V/7500	[N2]	48	45	2.6	0.00	450





## PAS 68 / IWA 14 CRASH TESTED SLIMLINE RISING BOLLARD

### Why Ezi Security Systems?

Ezi Security systems include:

- ▶ Flexibility to design to your requirements
- ▶ Manufacture & supply bespoke on and off products
- ▶ On-site project management and installations
- ▶ Street furniture available on PAS68 and IWA-14
- ▶ High security products available on PAS68-2010 and IWA-14



 **Ezi Security Systems**  
SERIOUS SECURITY IS EZI



# RETRACTABLE ANTI TERRORIST BOLLARDS RB002-40

IWA CRASH-TESTED (IWA-1: 2013 BOLLARD V/7200[N2A]/64/90:1.0)

**NO MAIN POWER NEEDED**



## AUSTRALIA'S PRODUCT OF THE YEAR 2019 (PHYSICAL SECURITY)

### Application

- ▶ Airport
- ▶ Sports Arenas
- ▶ Retails Parks
- ▶ Police Stations
- ▶ Critical Infrastructure
- ▶ Government Buildings
- ▶ Conference Centers



The new technology breakthrough in SHALLOW MOUNT RISING BOLLARD systems, it will keep bollard system and ground work costs to a fraction of the old large systems. This new patent granted bollard rising system is designed by our new Micro Engineering Divisions to cope with today's demand for shallow mount systems in both manual and hydraulic systems.

It requires no mains power as it is powered by cordless drill. RB002-40 it will stop a 7.2 tonne truck travelling at 40mph or 64 km at 90 degrees from breaking through the security line. On the other hand, RB003-50 it will stop a 7.5 tonnes running from 50mph or 80kph at 90 degrees from breaking through the security line. After impact both bollard still worked. This system is the most economical on the market for both bollards systems and installation. It is also very low maintenance, once fitted as a stand alone single unit, it can follow the contours of the ground.

After impact if the bollard or any parts in the system are damaged all the parts can be removed from the outer case that is concreted into the foundation and replaced. When fitted with a stainless steel bollard cover it is very aesthetically pleasing. These bollards are manually operated and require no mains power.

# RETRACTABLE ANTI TERRORIST BOLLARDS RB003-50

IWA CRASH-TESTED (IWA-1: 2013 BOLLARD V/7200[N2A]/80/90:3.1)

OPERATES WITH 18 VOLT CORDLESS DRILL

NEW PRODUCT



## SUPER SHALLOW MOUNT RETRACTABLE BOLLARD

### RB002-40 Product Specification

- ▶ Height Above Ground: 850mm
- ▶ Footing Depth: Only 400mm
- ▶ Bedding: 50mm
- ▶ Options: Stainless Steel & Mild Steel Shrouds Available



#### RB002-40 Slimline Rising Bollard

Vehicle Test Weight	Vehicle Class	Vehicle Speed kph	Vehicle Angle °	Vehicle Penetration	Footing Depth mm
IWA 14: V/7200	[N2A]	64	90	1.0	470
ASTM4: V/7200	[N2A]	64	90	P1	470

### RB003-50 Product Specification

- ▶ Height Above Ground: 950mm
- ▶ Footing Depth: Only 580mm
- ▶ Bedding: 50mm
- ▶ Options: Stainless Steel & Mild Steel Shrouds Available

#### RB003-50 Slimline Rising Bollard

Vehicle Test Weight	Vehicle Class	Vehicle Speed kph	Vehicle Angle °	Vehicle Penetration	Footing Depth mm
IWA 14: V/7200	[N2A]	80	90	3.1	630
ASTM	[F2656]	M50	90	P2	630

**Ezi Security Systems**  
SERIOUS SECURITY IS EZI

**safetyflex**  
ANTI-TERRORIST BOLLARDS

**ASIAL**  
MEMBER  
AUSTRALIAN SECURITY INDUSTRY ASSOCIATION LIMITED

**PSSA**  
Perimeter Security Suppliers Association  
AUSTRALIAN MEMBER







2018 AUSTRALIAN  
Security Industry  
AWARDS

SAFETYFLEX TRUCKSTOPPER 9-40 BOLLARD

# PRODUCT OF THE YEAR 2018

(PHYSICAL SECURITY)



## SAFETYFLEX TRUCKSTOPPER 9-40 BOLLARD BAGGED PRODUCT OF THE YEAR AWARD 2018

Ezi Security Systems is proud as punch to have won the Product of the Year Award 2018 under physical security, bollard, gate barrier and locks category. This award was given by Australian Security Industry Association Limited during the 23rd Annual Australian Security Industry Awards 2018.

Safetyflex Truckstopper 9-40 is a crash rated security solution with 7.5 tonne GVW Truck at 40mph/64kph with least penetration among its class. This features a robust blocking strength measured with only 2.4m ingress on impact.

While this security solution has proven toughness, Safetyflex truckstopper 9-40 only requires 20cm deep foundation which greatly reduced the need of re-diversion of utilities and labour.







#securityawards

2019 AUSTRALIAN Security Industry AWARDS

SAFETYFLEX RB002-40 RETRACTABLE BOLLARD

**PRODUCT OF THE YEAR 2019**

(PHYSICAL SECURITY)

RECOGNISING EXCELLENCE



## PRODUCT YEAR AWARD 2019: EZI SECURITY SYSTEMS BAGGED AWARD TWO YEARS IN A ROW

Ezi Security Systems once again went home with the Product of the Year Award 2019 under physical security, bollard, gate barrier and locks category, October 17, 2019.

The award was given by Australian Security Industry Association Limited during the 23rd Annual Australian Security Industry Awards 2018 to Safetyflex RB002-40 at Park Hyatt, Melbourne.

Safetyflex RB002-40 is a crash rated security solution with 7.2 tonne at 40mph/64kph at 90°. This bollard system requires a lessened ground work cost compared to other old large systems.

With foundation requirements of only 47 cm deep foundation, this solution also has reduced operational power cost as the system is fully operable with cordless drill.





**NSW**

Head Office  
Smithfield NSW 2164

1300 558 304

sales@ezisecurity.com

**QLD**

Satellite Office

1300 558 304

sales@ezisecurity.com

**VIC, SA, & TAS**

Satellite Office

1300 558 304

sales@ezisecurity.com

**ACT**

Satellite Office

1300 558 304  
0412 120 984

sales@ezisecurity.com

For all sales / service enquiries please contact us below:  
sales@ezisecurity.com  
1300 558 304

Should you require information on the full Ezi Security Ausytralia range of products, please visit our website:  
www.ezisecurity.com.au



Find out more about us!

www.ezisecurity.com.au

☎ 1300 558 304

**Ezi**® Ezi Security Systems  
SERIOUS SECURITY IS EZI

a 11 Cooper St Smithfield 2164  
t 1300 558 304  
e sales@ezisecurity.com.au

