



# HEAVY INDUSTRIAL SLIDING GATE SYSTEM



**Ezi Security Systems**  
SERIOUS SECURITY IS EZI

## HEAVY INDUSTRIAL SLIDING GATE SYSTEM

The Ezi Heavy Industrial Sliding Gate System is based on the principles of counter balancing. These systems are designed and engineered to Ezi's exacting calculations and standards with a strong emphasis on safety.

Each Heavy Industrial Sliding Gate System comprises the following important mechanical modules. The modules consist of the gate main support tower, the gate leaf, the gate back rail and the end post. When bolted together, the main tower and back rail form the main support and rolling platform for the gate leaf. The gate leaf is then attached to this platform with two back-check plate roller sets. The roller sets, when bolted on, lock the sliding gate leaf within the confines of the gate back rail.

The gate system is then bolted to a concrete footing that has been engineered to provide adequate weight to counter-balance the gate system. The combination of gate design and concrete footing allows the gate to roll out over the relevant road opening, without tipping or sagging, basically traveling in free air.

Up to 10 metre road widths (for a single gate) are standard within our product range. The Heavy Industrial Sliding Gate System needs no road rails, tracks or overhead supports.

Each Ezi Slide Gate is designed with automation features as standard. An industrial three-phase drive motor, PLC control logic, frequency inverter and proximity sensors are some of the highly advanced products used in Ezi's product range. Each Ezi PLC system allows for special features and auxiliary equipment to be added without major parts redundancy. e.g. traffic light controls, card access readers.

Our main support and rolling platform is well balanced and provides smooth and efficient operations. Our standard cantilevered designs operate at variable speeds. These are adjustable to a maximum of 800mm per second of gate travel.

The Heavy Industrial Sliding Gate System is not affected by road crowns, kerbs or falls for drainage in roads. All associated works to install a Heavy Industrial Sliding Gate System are performed off to the side of the relevant road, thereby avoiding closures, which can be inconvenient and costly to your business.

The Ezi Heavy Industrial Sliding Gate System has no equal in the industrial market place. Each system will perform reliably all day, every day.

***"AT EZI, WE BELIEVE SAFETY SHOULD NOT BE AN OPTION. THAT IS WHY OUR SYSTEMS HAVE BEEN FULLY RISK ASSESSED TO BEST STANDARDS"***

Our systems have been fully risk assessed to contemporary OH&S standards by an independent authority. Ezi Heavy Industrial Sliding Gate System has an extensive array of safety devices and features which form part of our standard product offering.

Our wealth of knowledge and experience gained over the years has enabled Ezi to evolve and develop this premium product to suit a variety of ever-changing environments. The Ezi Heavy Industrial Sliding Gate Systems, as developed by Ezi, are purpose-built for the industrial market place. The key consideration is safety of operation without compromise to security. High levels of performance, aesthetically pleasing design and unrivalled reliability are also a feature.

The high performance and advanced technology built into the Ezi Slide Gate will ensure reliable operation for many years to come. Ezi boasts a large end-user customer base and continues to provide product and service to Australia's leading corporations.

\*\* EZI MASTER MANUAL CANTILEVERED SLIDING GATE ARE ALSO AVAILABLE

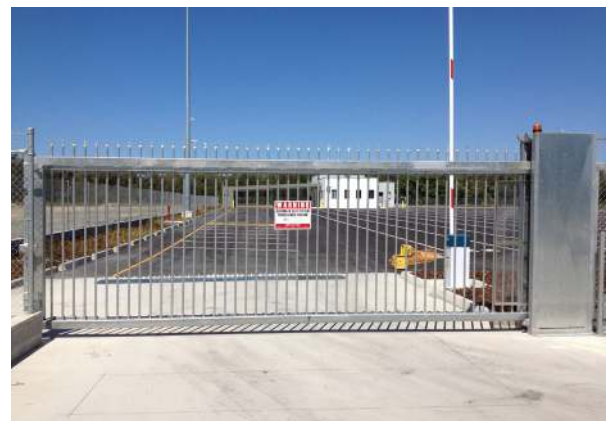

## STANDARD TECHNICAL SPECIFICATION

Gate width	3 metres to 12 metres (custom available)
Gate height	2200mm standard
Gate clearance	150mm nominal
Gate erected height	2350mm nominal
Gate frame	100mm sq RHS (minimum)
Gate end post	100mm sq RHS
Gate tower	100mm sq RHS
Gate tower height	2500mm nominal
Gate tower cladding	Galvanised sheet metal (1.6mm)
Gate back rail	102mm I beam
Gate finish	Hot dip galvanised (optional 2 pack paint)
Gate bearings	Fully sealed
Guide rollers	Black PVC nylon
Main rollers	Zinc plated, mild steel (40 ton rated)
Motor release	Throw over quick release
Motor	0.75kw three phase brake motor
Gearbox	Worm drive (ratio's variable)

Drive cog	Industrial grade nylon or brass
Drive rack	25mm sq zinc plated mild steel
Control logic	True PLC, 24v DC
Drive logic	VSD 240v single phase to 240v three phase
Power supply	Regulated 240v to 24v DC
Control enclosure	IP56, mild steel, painted, 600 x 400 x 200
Position sensing	Proximity sensors, NPN 24v DC
Safety (pedestrian)	Photo electric cells, 24v DC, fail safe
Safety (vehicle)	Inductive loops & detectors, 24v DC, fail safe
Gate duty cycle	True 100% cycling as per Ezi's standard
Power requirement	240v, 15 amp supply
Current draw	4 amp running, 8 amp start up
Strobe light	Orange, 24v DC
Piezo	24v DC (pulsing)
Polycarbonate	High impact safety screen

## STANDARD TECHNICAL DRAWING

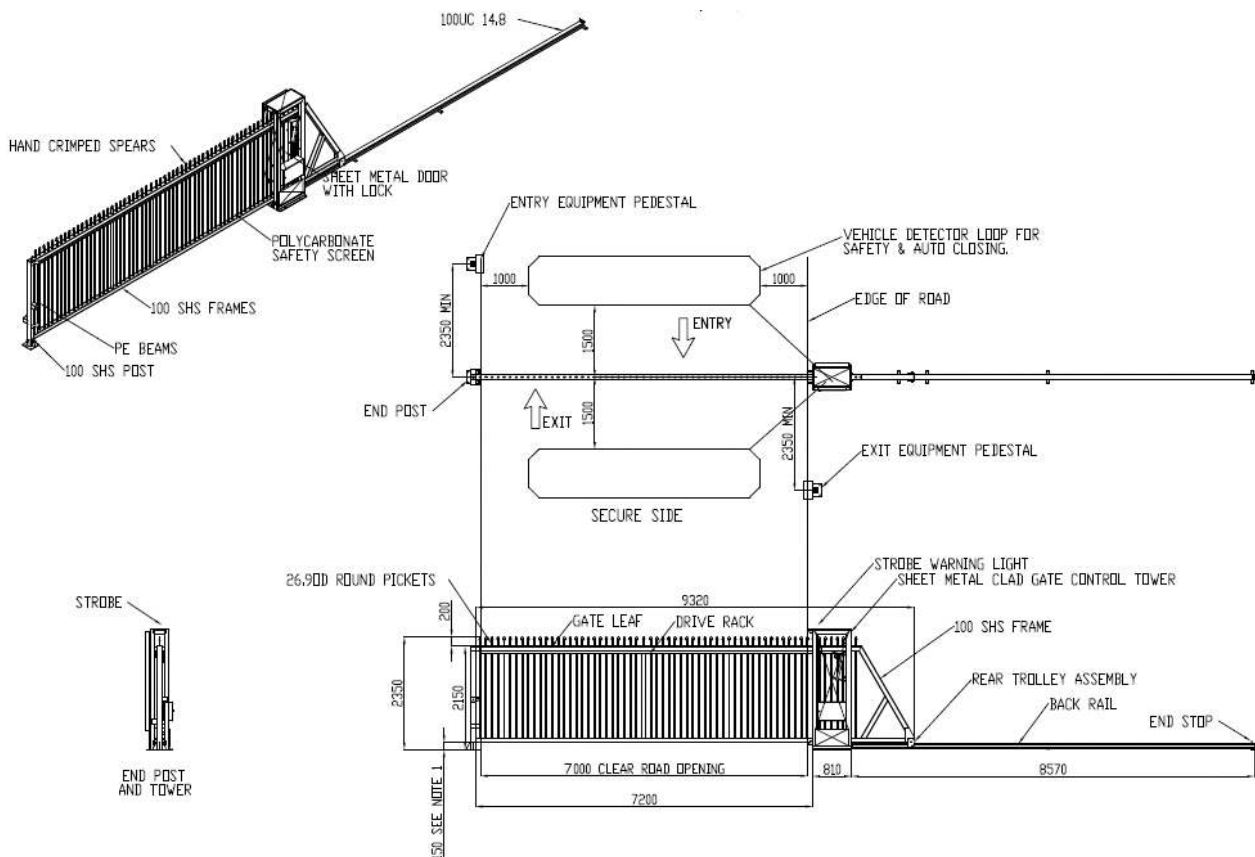



**Ezi Security Systems**

S E R I O U S   S E C U R I T Y   I S   E Z I

## OUR PRODUCTS AVAILABLE

### CRASH RATED RANGE



### TRADITIONAL RANGE



### WERRA RANGE

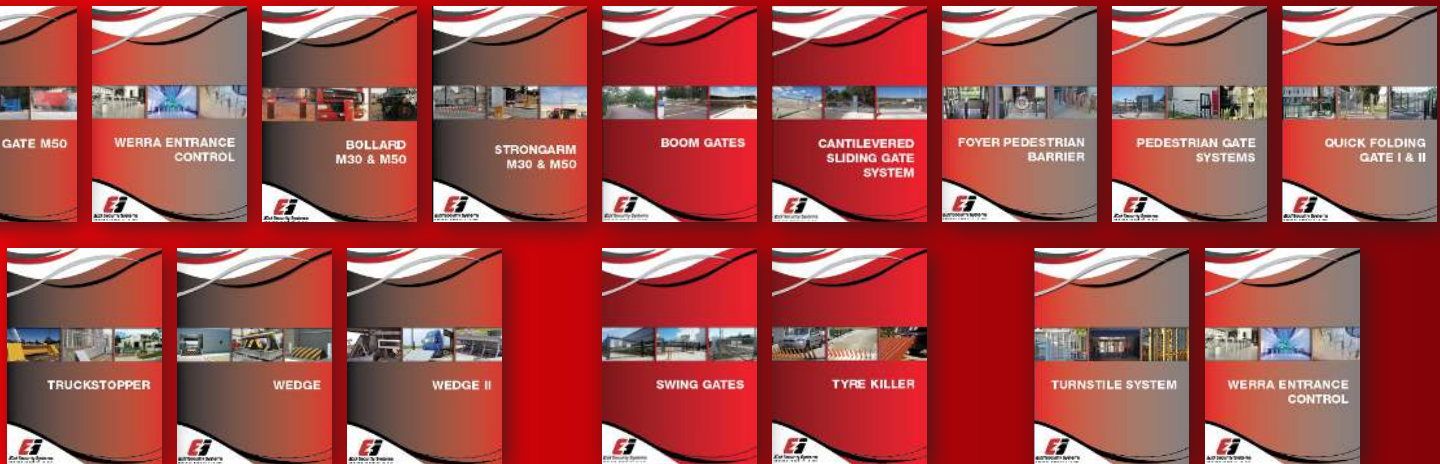

## FOLLOW US ON



# AUSTRALIA NATIONAL

# 1300 558 304

**11 Cooper Street Smithfield NSW 2164**

[www.ezisecurity.com.au](http://www.ezisecurity.com.au)

**Email:** [sales@ezisecurity.com](mailto:sales@ezisecurity.com)