



WEDGE II

CERTIFIED TO



Ezi Security Systems
SERIOUS SECURITY IS EZI

WEDGE II

Elkosta Wedge II is designed to guarantee the full level of security. Typical areas of application are embassies, government seats, research and development centres, power stations, industrial plants, military sites, airports and other high security areas. It can be installed as a single unit or in combination with other products (e.g. barriers, gates, tyre killers or bollards) in order to realise a sluice arrangement forming a vehicle check point.

"THE WEDGE II IS ALSO SUITABLE FOR INSTALLATION IN CITY CENTRES DUE TO ITS SHALLOW FOUNDATION DEPTH OF ONLY 300MM"

The new elkosta Wedge II was successfully tested to PAS 68:2013 and IWA 14-1:2013 standard stopping a 7.5 t vehicle travelling at 80 km/h with ZERO penetration. With its decreased installation depth and foundation footprint combined with the lowest foundation thickness in the world, the new Wedge II reduces installation costs significantly and allows installation in areas where foundation depths are limited due to underground utilities. Compared to the previous model, the Wedge II features many technically innovative details, like state of art foundation and reinforcement. It offers high energy efficiency due to employment of pressure spring pistons. Starting power and lifting power for raising of blocking element due to energy stored in pressure springs have been optimised as well.

Further improvements are the scale downed versions of accumulator for EFO and RO3 function. The Wedge II effectively blocks the road within 3 sec., decreasing to 1 sec. (via optional accumulator). The

working oil volume is reduced due to use of a single hydraulic cylinder. This means lower costs for higher security.

Available control options

- ◆ Certified with a blocking width of 4m according to the following performance classifications:
 - ◆ PAS 68:2013 V/7500[N3]/80/90:0.0/20.7
 - ◆ IWA 14-1:2013 V/7200[N3C]/80/90:0.0
- ◆ Extremely fast operation (approx 1 sec EFO option)
- ◆ State of art foundation and reinforcement
- ◆ Only 300mm installation depth (200mm foundation thickness + 100mm below road covering)
- ◆ With or without safety skirt - one version for all requirements
- ◆ Reduced working oil volume due to single hydraulic cylinder
- ◆ Scale-downed versions of accumulator for EFO and RO3 function
- ◆ Compact and easy to install assembly unit
- ◆ Easy assembly for effortless maintenance
- ◆ LEDs available as optional extra

** EZI MASTER MANUAL WEDGE II ARE ALSO AVAILABLE



STANDARD TECHNICAL SPECIFICATION

Design	Wedge with electro-hydraulic drive in separate drive cabinet. Optional: Wedge fitted with safety skirt	
Impact Load	1852 kJ (7.5 t @ 80 km/h) Certified according to PAS68 V/7500[N3]/80/90:0.0/20.7 and IWA 14-1 V/7200[N3C]/80/90:0.0	
Blocking Width	2.0m, 2.5m, 3.0m, 3.5m and 4.0m	
Blocking Height	1000mm	
Base frame	L x W x H: (blocking width + 200mm) x 1950mm x 300 mm	
Drive Cabinet	H x W x D: 1400mm x 1200mm x 400mm incl. 200mm high base	
Emergency Operation	Via hand pump (standard) Accumulator incl. rechargeable batteries for 3 movements (RO3) (optional)	
Operating Times	Raising: approx. 3.5 sec, lowering: approx. 3.5sec (standard) Emergency fast operation (EFO): approx. 1sec (with optional accumulator)	
Wheel Load	100kN according to SLW60 – DIN 1072	
Drive	4.0kW, 400V (three-phase), 50Hz	
Hydraulic Fluid	Mineral oil HLP 22 or biodegradable oil Plantohyd 22 S, non-hazardous to water	
Control unit	PLC in control box installed in drive cabinet (standard), PLC in separate control box for wall mounting inside a building (optional), control voltage 24V	
Supply voltage	400V (3Ph + N + PE), 50Hz	
Control Box	Control unit configuration STANDARD: HxWxD = 400x400x200mm, IP 66 Control unit configuration STANDARD: HxWxD = 400x400x200mm, IP 66 Control unit configuration VARIO BASIC: HxWxD = 600x400x200mm, IP 66 Control unit configuration VARIO EFO: HxWxD = 600x400x20mm, IP 66 Control unit configuration VARIO RO3: HxWxD = 800x400x300 mm, IP 66	
Weight	Approx. 1500 – 2000 (wedge) Approx. 280 – 400kg (drive cabinet)	
Lighting (Optional)	LED-strip lighting and front cover fitted to impact beam	
Colour (Standard)	Blocking element	RAL 7030 stone grey
	Base frame	RAL 7030 stone grey
	Cover plate	RAL 7030 stone grey
	Scissor joints	RAL 3000 flame red
	Hydraulic cylinder	RAL 3000 flame red
	Drive cabinet	RAL 7035 light grey
	Optional safety skirt	RAL 3000 flame red
Colour (Optional)	Cover plate	V-striped RAL 1007 daffodil yellow / RAL 9005 jet black, V-striped RAL 3000 flame red / RAL 9010 pure white cross striped RAL 1007 daffodil yellow / RAL 9005 jet black cross striped RAL 3000 flame red / RAL 9010 pure white or other RAL colours or DB colours
	Optional safety skirt	Scissor joints, hydraulic cylinder, blocking element and base frame: other RAL colours
Temperature range	-20°C – 60°C	

STANDARD TECHNICAL DRAWING

Wedge II standard configuration

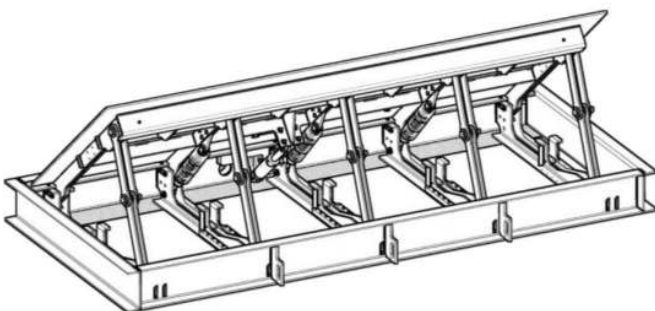

Wedge II with optional safety skirt and LED-strip lightening

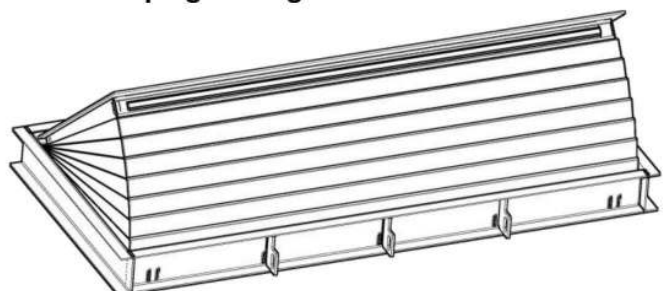



Ezi Security Systems

S E R I O U S S E C U R I T Y I S E Z I

OUR PRODUCTS AVAILABLE

CRASH RATED RANGE

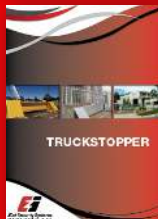

FOLLOW US ON



AUSTRALIA NATIONAL

1300 558 304

11 Cooper Street Smithfield NSW 2164

www.ezisecurity.com.au

Email: sales@ezisecurity.com